



KEY SPECS

Platform Height
13.72 m

Up and Over Height
7.70 m

Horizontal Outreach
7.24 m

Platform Capacity
230 kg

KEY FEATURES

- Achieve maximum manoeuvrability over uneven surfaces with Automatic Traction Control.
- Achieve optimum productivity with longer duty cycles.
- Produces zero emissions and is 100% environmentally friendly.
- Improved up-and-over reach with articulating jib.

ACCESSORIES & OPTIONS

- 0.76 m x 1.22 m low-mount platform swing gate
- 0.76 m x 0.91 m low-mount platform, rear entry **
- 13 mm air line to platform
- 240/55 - 17.5 foam-filled tires -black rubber
- Platform work lights
- Head and tail lights
- Plugs & sockets
- Programmable Security Lock
- Synthetic biodegradable Hydraulic Oil
- Acrylic console shield
- Cylinder bellows
- Skyline with beacon
- Beacon red colour

* Provides indicator lights at platform control console for system distress, low battery, tilt light, and foot switch status.
** Available only with drop bar type entry

STANDARD SPECIFICATIONS

Performance

Working Height	15.72 m
Platform Height	13.72 m
Horizontal Outreach	7.24 m
Working Outreach **	7.89 m
Up and Over Height	7.70 m
Swing (non-continuous)	360°
Platform Capacity - Unrestricted	230 kg
Platform Rotator (Hydraulic)	180°
Jib - Overall Length	1.24 m
Jib - Range of articulation	144° (+84°/ -60°)
Machine weight *	6,670 kg
Maximum Ground Bearing Pressure	5.3 kg/cm ²
Drive Speed	5.2 km/h
Gradeability	30%
Turning Radius - Inside	0.61 m
Turning Radius - Outside	3.15 m

* Certain options or country standards may increase weight and/or dimensions.
** Horizontal outreach + 0.65 m

Power Source

Electrical System	48 V DC
Batteries	8 x 6V 370 A/hr AGM
Drive Motors	Dual AC Traction

Tires

Non marking	240/55-17.5 Foam-filled
Brakes	Automatic Spring Applied

Hydraulic System

Hydraulic Motor	DC Electric motor
Hydraulic Pump	Gear Pump
Hydraulic System	20 L

STANDARD FEATURES

- 0.76 m x 1.52 m low-mount platform swing gate
- Multi-function operation
- Full proportional drive joystick control with integral thumb steer switch
- Full proportional main boom and swing joystick control
- Multi-speed control for lower boom, telescope, jib and platform rotation
- Selectable creep speed for drive / lift and swing functions
- 1.22 m articulating jib
- 180-degree powered platform rotator
- Platform console machine status light panel *
- Load sensing system
- AC power cable to platform
- Two-wheel Direct Electric Drive with AC motors
- 8 x 6V 370 A/hr AGM Batteries
- 8 x 6V 370 A/hr deep-cycle batteries
- Automatic traction control
- Programmable "Personality" settings
- On-board self-diagnostic testing
- Enclosed battery / electrical compartment
- 20 amp automatic battery charger
- Automatic rear wheel brakes
- 3 degree tilt alarm and indicator light
- Non-marking solid rubber tires
- 240/55 - 17.5 non-marking foam-filled tires
- Lifting/tie-down lugs
- Ground control selector switch with key lock
- Battery condition indicator
- Hour meter
- Horn
- 305 A/hr maintenance free AGM batteries in lieu of standard
- All-motion alarm
- Amber strobe light
- Skyline active enhanced protection system
- Skyline without beacon
- Platform tool tray
- Manual descent system
- ClearSky SMART FLEET connectivity module - Subscription through Online Express

E450AJ

ELECTRIC BOOM



DIMENSIONS

All dimensions are approximate

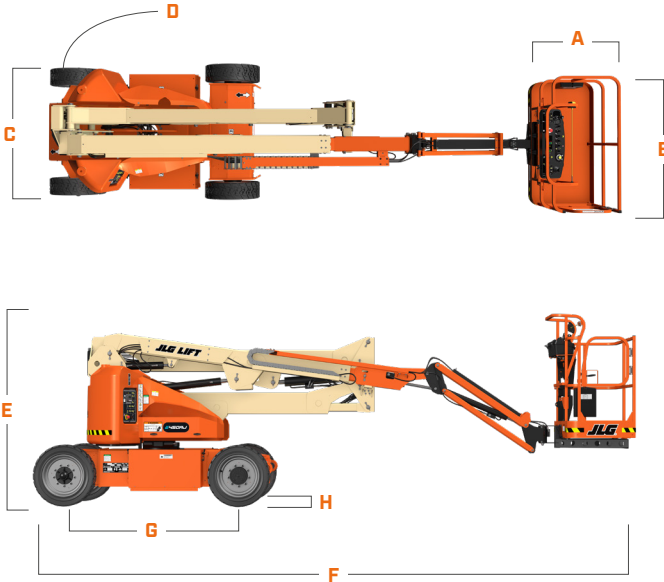

A. Platform Width	0.76 m
B. Platform Length	1.52 m
C. Overall Width	1.75 m
D. Tailswing (working condition)	Zero
E. Stowed Height	2.01 m
F. Stowed Length	6.45 m
G. Wheelbase	2.01 m
H. Ground Clearance	0.20 m

REACH DIAGRAM

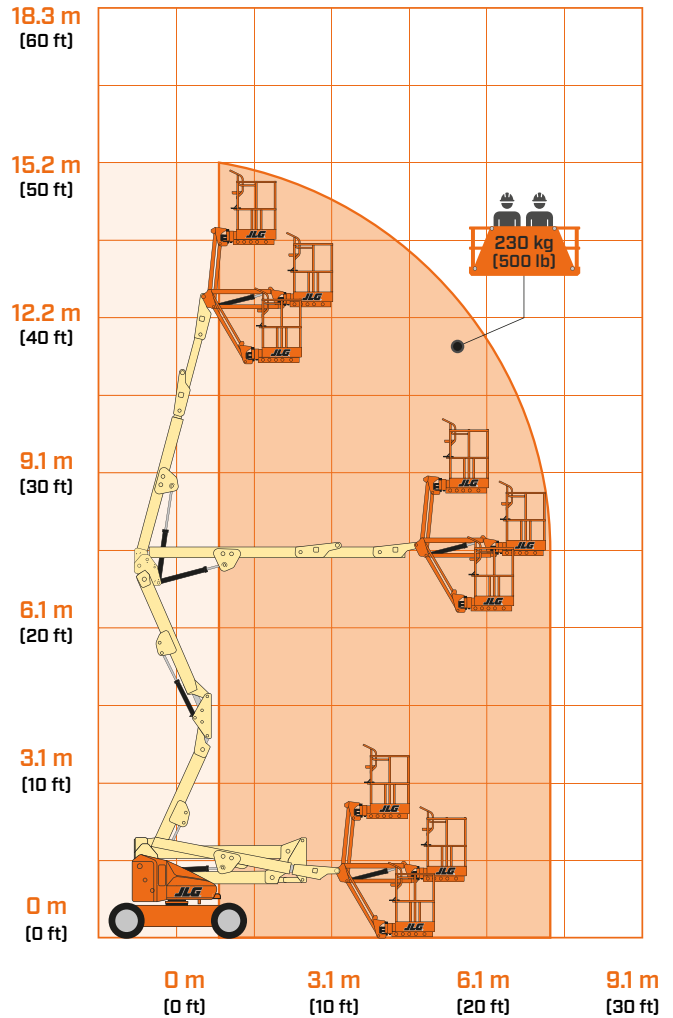

IMPORTANT

JLG is continually researching and developing products and reserves the right to make modifications without prior notice. All data in this document is indicative. Certain options or country standards will increase weight. Specifications may change to meet country standards or with the addition of optional equipment.

Due to continuous product improvements, JLG Industries reserves the right to make specification and/or equipment changes without prior notification.



JLG EMEA BV
 Polaris Avenue 63
 2132 JH Hoofddorp
 The Netherlands
 Tel.: +31 (0)23 565 5665
www.jlg.com

An Oshkosh Corporation Company